

Anna-Liz

A New Core for Debugging PCI Designs

A new PCI core that solves a wide range of problems including transaction duration measurement, retry analysis, and post-mortem analysis.

by Edgard Garcia, Xilinx
Consultant, Multi Video Designs,
edgard.garcia@mud-fpga.com

“Anna-Liz” is a 33-MHz PCI bus analyzer core developed by the French company Multi Video Designs. It can be associated with any version of Xilinx PCI LogiCORE (because it fits in the “Userapp” module of the top-level schematic) and can be mixed with any related design without extra hardware. You can use it in a separate board (any type of PCI board using the Xilinx PCI Interface) or include it in an existing design.

Analysis Capabilities

Anna-Liz (Figure 1) captures PCI cycles and stores related data according to a programmable mask on addresses and transaction codes. During an address cycle an 8-bit counter is reset and its value is stored concurrently with the data. Up to 31 transactions can be analyzed. Addresses, Data, CBE[3:0], IRDY#, TRDY#, DEVSEL#, and STOP# are snooped on the PCI bus and stored in CLB RAMs (32x84) together with the duration counter.

Storage is limited to a depth of 32 – 1 for pipelining reasons; LOCK#, SBO#, SDONE#, and REQ#/GNT# are not analyzed.

The information is stored internally only if the mask matches and when IRDY# and TRDY# (or STOP#) are active. A valid disconnect, with and without data and abort cycles, can therefore be stored.

The basic version uses an 84x32 synchronous memory arranged as follows:

- 32 bits for address.
- 32 bits for data.
- 4 bits for transaction code.
- 4 bits for byte enables.
- 3 bits for TRDY#, STOP#, and DEVSEL# values.
- 1 bit for burst signaling.
- 8 bits for cycle counter.

Analyzing Configuration Cycles (Read and Write) in the Range 1340-134F

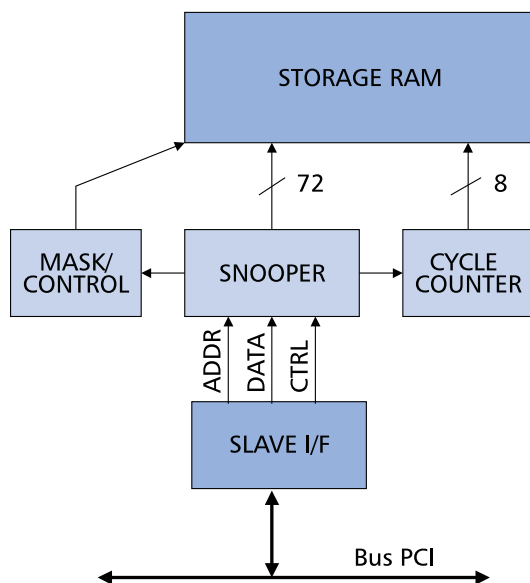

Figure 1

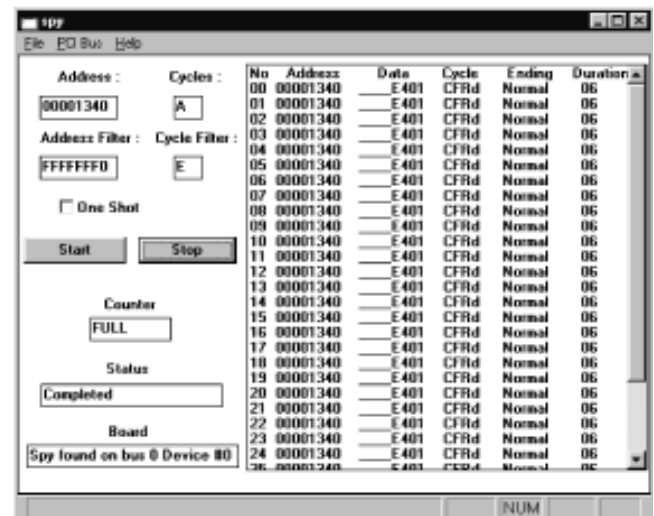

Figure 2

Anna-Liz can save you a lot of time and trouble when you are developing PCI-based products.

A programmable bit selects either single-shot or a continuous storage. In single-shot mode, storage stops when the capture memory is full. In continuous mode, storage stops when you issue a software command.

If the RESET# signal is disconnected from the device, the capture memory is not cleared when resetting the target system, so Anna-Liz can be used for post-mortem analysis; this can be very useful during testing.

Software Support

Anna-Liz is supported by DOS and Windows:

- The DOS version includes an initialization program associated with a result analyzer program. Initialization is made by a single line command which includes Hex mask programming (to filter specific transactions). Some shortcuts are available for transaction code masking. The result analyzer program displays captured cycles using a clean and understandable form (text form with text display of transaction type and end of transaction). Other programs allow displaying of PCI and mother board capabilities.

Analysis is started by executing the setspy.exe program (parameters are defined in the command line).

- The Windows version includes the DOS programs in a single window with easy-to-use commands and displays

(command buttons and control windows). Results are displayed as text in a window. Analysis is started by clicking on a button (parameters are defined in specific windows).

- Source code (C/C++) is included with the product and can be very easily adapted to any specific use. PCI BIOS accesses were written in assembler for better portability.

Implementation

Anna-Liz was developed in Viewdraw, and source code is included in the product, making specific adaptations very easy to do. For example, a scope synchronization output can be added very easily. Anna-Liz works with any Xilinx LogiCORE-based PCI interface. It only needs a slave core plus 280 CLBs, and uses a single I/O base (32 bytes). It can be mixed with an existing design if the target part holds enough room, or implemented as stand-alone on any existing board.

Spartan, Spartan XL, and XC4000E/XLA/XLT devices can be used (Virtex version to be issued soon).

Conclusion

Anna-Liz can save you a lot of time and trouble when you are developing PCI-based products. ✘

See page 27 for more information on Multi Video Designs.

Help Window Displaying PCI Command Codes

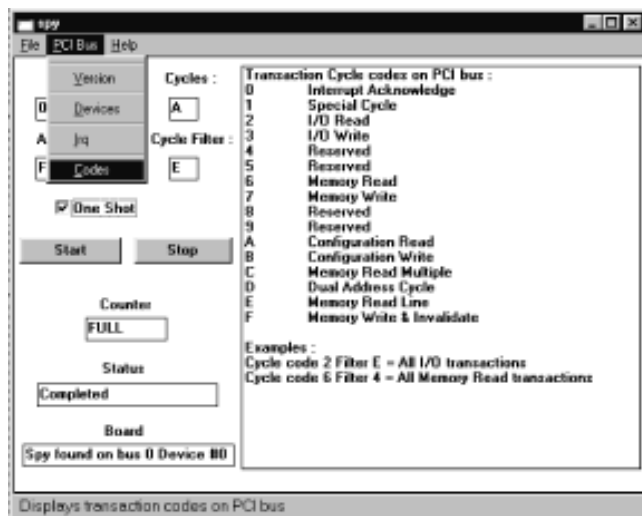

Figure 3

Displaying the Available Devices and Configuration Registers on the Target Machine

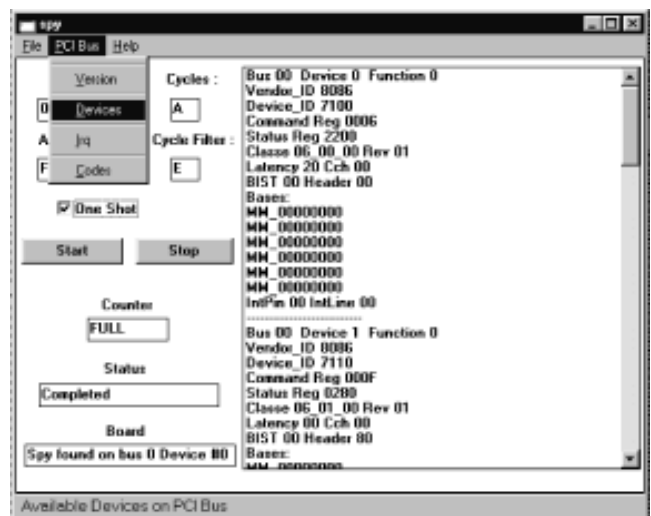

Figure 4